

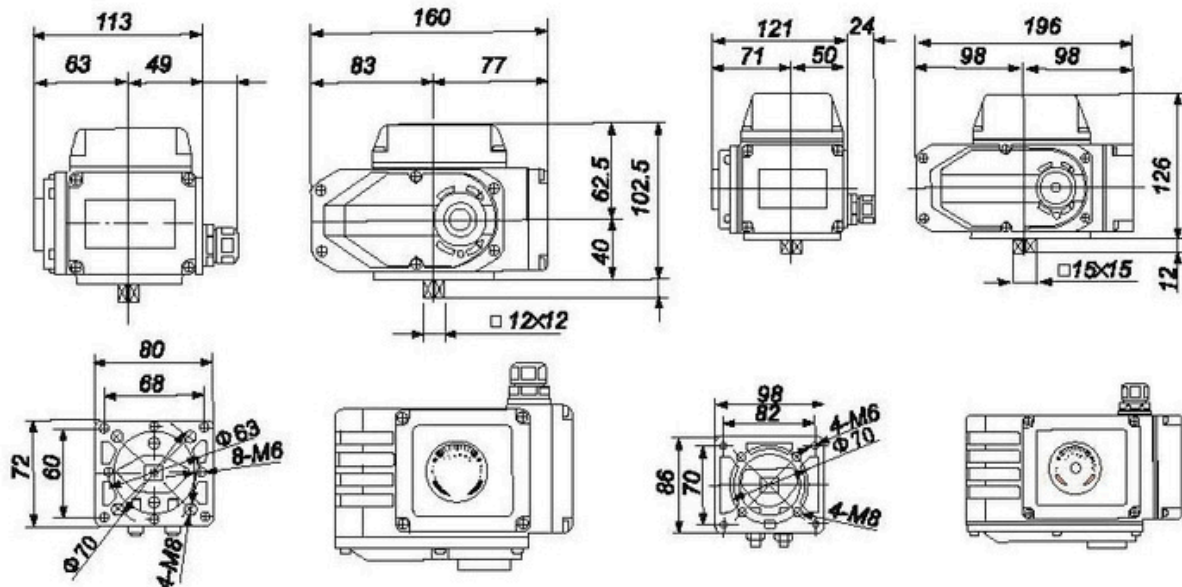

Dimension and Parameter

TQA 05

TQA-10



Type	TQA-05	TQA-10	TQA-15
Performance			
Output torque	50Nm	100Nm	150Nm
90°stroke time	20S/60S	30S/60S	30S/60
Fum around angle scope	0~90°	0~90°	S 0~90°
Machine power	15W	25W 3kg	30W
Machine weight	2kg		3.5kg
Voltage	AC110V、AC220V、AC380V、DC24V		
Insulation resistance	100M/500VDC		
Pressure resistance	1500VAC 1min		
Protection rank	IP65、67		
Install position	360°arbitrary angle install		
Electric interface	G1/2Waterproof cable fitting、 power line signal line each have one.		
Environmental temperature	-30°C~+60°C		
The control circuit choice	A type:Terminal position switch (standard ON/OFF type) S type:With potentiometer R type:With potentiometer RS type:With potentiometer and middle position switch P type:With servo controller(Modulating type)		
Optional function	Dehumidificationheater Stainlesssteelsupport,shaftcoupling		



Dimension and Parameter

TQA-20、TQA-40、TQA-60

TQA-100、TQA-200

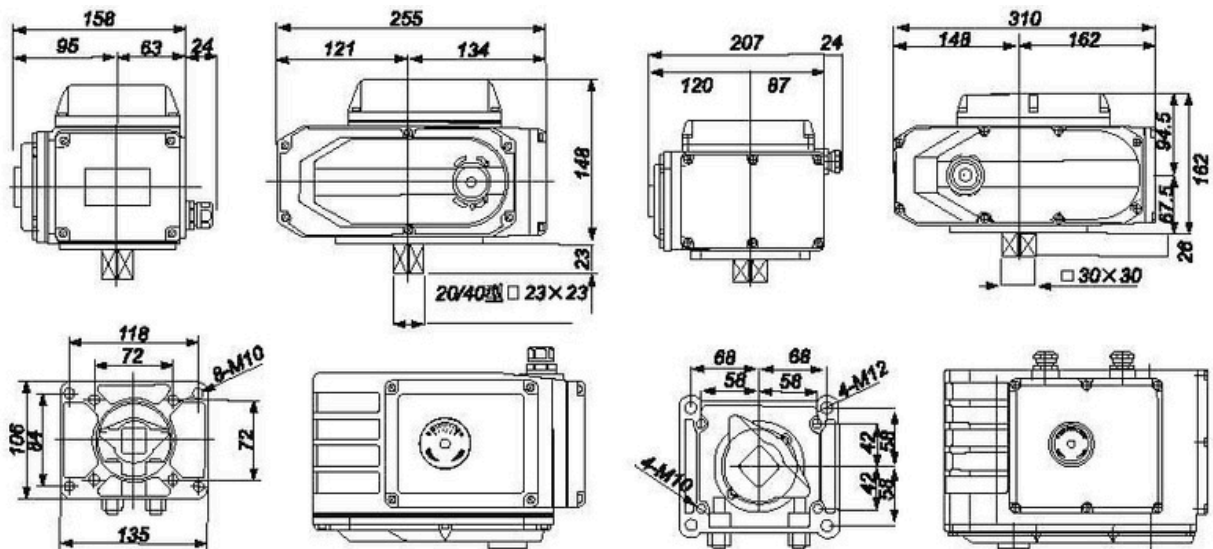

Type	TQA-20	TQA-40	TQA-60	TQA-100	TQA-200
Performance					
Output torque	200Nm	400Nm	600Nm	1000Nm	2000Nm
90°stroke time	30S/60S	30S/60S	45S	50S 0~90°	100S
Fum around angle scope	0~90°	0~90°	0~90°	120W	0~90°
Machine power	45W	60W	90W	17kg	120W
Machine weight	8kg	8.5kg	9.0kg		18kg
Voltage	AC110V、AC220V、AC380V、DC24V				
Insulation resistance	100M/500VDC				
Pressure resistance	1500VAC 1min				
Protection rank	IP65、67				
Install position	360°arbitrary angle install				
Electric interface	G1/2Waterproof cable fitting、 power line signal line each have one.				
Environmental temperature	-30°C~+60°C				
The control circuit choice	A type:Terminal position switch (standard ON/OFF type) S type:With potentiometer R type:With potentiometer RS type:With potentiometer and middle position switch P type:With servo controller(Modulating type)				
Optional function	Dehumidificationheater Stainlessteelsupport,shaftcoupling				



Modulating type(M type)complete machine performance index

Performance \ Type	TQA-05M	TQA-10M	TQA-15M	TQA-20M	TQA-40M
Output torque	50Nm	100Nm	150Nm	200Nm	400Nm
90°stroke time	20S	30S/60S	30S/60S	30S/60S	30S/60S
Tum around angle scope	0~90°	0~90°	0~90°	0~90°	0~90°
Machine power	15W	25W 3kg	30W	45W	60W
Machine weight	2kg		3.5kg	8kg	8.5kg
Voltage	AC220V、AC110V、AC380V				
Input signal	4~20mA OR 0~10V				
Output signal	4~20mA OR 0~10V				
Error range	No exceed $\pm 0.5\%$				
Backlash	Less than 0.3%				
Dead zone	0.1%~1.6% Adjustable				
Damping feature	0				
Organization's repeated error	0%				

Performance \ Type	TQA-60M	TQA-100M	TQA-200M
Output torque	600Nm	1000N	2000N
90°stroke time	45S	m 50S	m 100S
Tum around angle scope	0~90°	0~90°	0~90°
Machine power	90W	120W	120W
Machine weight	9.0kg	17kg	18kg
Voltage	AC220V、AC110V、AC380V		
Input signal	4~20mADC、1-5VDC		
Output signal	4~20mADC		
Error range	No exceed $\pm 0.5\%$		
Backlash	Less than 0.3%		
Dead zone	0.1%~1.6% Adjustable		
Damping feature	0		
Organization's repeated error	0%		